



Store these instructions in a safe place or with the enclosed maintenance checklist

# Instruction Sheet

## Floor Mirror w/Chalkboard 2245



Take time to familiarize yourself with the use and maintenance of this equipment before using. Please file this Instruction Sheet in an accessible location: the Instruction Sheet must be read and familiar to anyone who is using Southpaw Enterprises Equipment.

**IMPORTANT: Please check equipment immediately for any damage that may have resulted during shipping. If any damage has occurred, please contact Southpaw Enterprises, Inc. immediately.**

### MATERIALS LIST

- 2 - Side Supports
- 1 - Mirror / Blackboard with fixed side bolts
- 2 - Black Plastic Knobs
- 4 - Large Washers
- 1 - Instruction Sheet
- 1 - Maintenance Checklist

**IMPORTANT: Keep all parts together.**

### ASSEMBLY PROCEDURES

1. Remove the knobs and one washer from each side of the mirror.
2. Slide side support onto bolt, followed by a washer and then the knob. Repeat on other side.
3. Tighten knobs firmly. **DO NOT OVER TIGHTEN!**
4. To remove the protective covering from the mirror, lift at edges. If there is any difficulty removing the sheeting, use aliphatic naphtha, kerosene, or distilled alcohol to moisten the adhesive. Do not use other chemicals or sharp objects to remove the sheeting.

### TO ADJUST THE ANGLE OF THE MIRROR

1. Loosen Black knobs Fig. 1
2. Move mirror/blackboard to desired angle.
3. Tighten knobs firmly.

### SPECIAL NOTES

- The floor mirror is not designed to be used parallel to the floor in a table-like manner.
- Do not use tape on mirror surface.

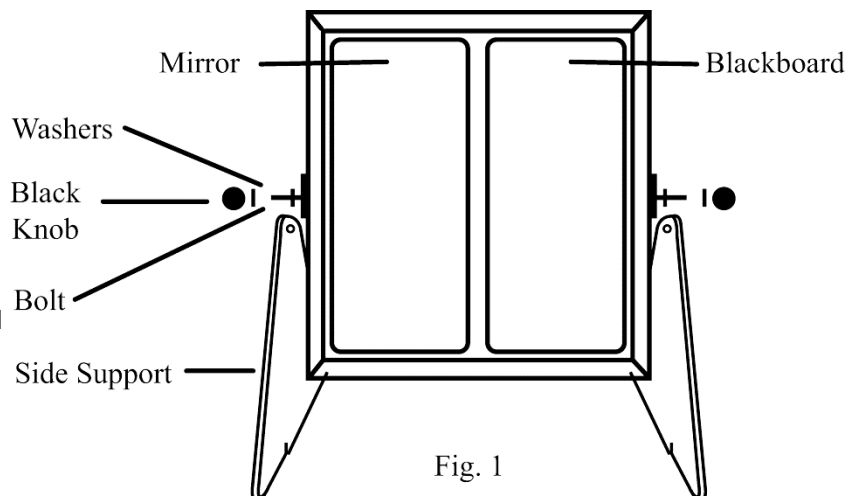

Fig. 1

## MAINTENANCE CHECKLIST

All of the following wear points should be checked on a monthly basis and recorded on the checklist enclosed.

- Check all wooden parts for chips or splinters. Sand smooth and refinish with polyurethane or discontinue use.
- Check for scratches on mirror. Small scratches can be removed by hand polishing with a plastic scratch remover or compound cleaner. Remove all residue and polish with a flannel cloth.
- Check hardware to make sure it is securely attached. If hardware is not securely attached, tighten screws. If it is still not secure call Southpaw for repair or replacement.

## STORAGE PROCEDURES

- Store out of direct sunlight. Sunlight will yellow the mirror surface.
- Store where not accessible by clients without proper supervision.

## CLEANING INSTRUCTIONS

Check with your infectious disease department before using these procedures.

- Check for client allergies first.
- *Wood* parts can be dusted as needed. If necessary, wood can be cleaned with a damp cloth using soap and water or disinfectant. Dry before using.
- *Mirror cleaning instructions:* **Do not use window sprays or kitchen scouring compounds.** Water cannot be used freely on the mirror. The mirror should be first dusted very lightly (not wiped) with a *soft* clean cloth. Then use a mild dish soap, water and a soft cloth to wipe the surface. Apply only light pressure. Grease and oil may be removed with kerosene or aliphatic naphtha (no aromatic content). Do not use solvents such as acetone, benzene, carbon tetrachloride, dry cleaning fluid, or lacquer thinner as they attack the mirror surface.
- A surface gloss can be maintained by occasionally using a flannel cloth and a good plastic cleaner or polish such as Johnson's Pledge. Follow the instructions on container.
- The *blackboard* surface may be cleaned using a damp cloth.

## CAUTION

- ◆ **MATTING PRECAUTIONS:** Always use appropriate matting.
- ◆ **SAFETY NOTES:** Mirror should not be placed in high traffic area. Do not allow client's to sit or climb on Floor Mirror.
- ◆ **WARNING:** Plexiglass has been known to break upon impact. If cracked, discontinue use immediately and contact Southpaw for repair or replacement.

**Safety Precautions** - The safety of your clients is dependent on the appropriate choice of activity to match, yet challenge their physical abilities. Use appropriate spotting / safety techniques. In addition, the layout of your activity area, proper installation and maintenance of your equipment is critical. Southpaw equipment is not intended for recreational or outdoor use. Under no condition should this equipment be used without proper supervision.

**This sheet is for example only.** It is not meant to, in any way, replace local, county, state, or Federal standards. Be aware - it is your responsibility to find all pertinent safety information that pertains to your facility.

If you have any questions or comments, please call or write

Southpaw Enterprises, Inc.

P.O. Box 1047, Dayton, Ohio 45401 -1047

Toll Free - (800) 228-1698

Please visit us at [www.southpaw.com](http://www.southpaw.com)

© 2019 Southpaw Enterprises, Inc.