



Store these instructions with the enclosed maintenance checklist in a safe place. You may also access them on our website.

Instruction Sheet 7066

Wood Joist 2-1/2 to 5 ft. Ft. Drop Ceiling Kit



WARNING! Eye bolts will wear with use and must be inspected on a regular basis.

Discontinue use of eyebolt and replace immediately when wear begins to show.

Do not let wear exceed 30% of the eye bolt.

IMPORTANT: Please check equipment immediately for any damage that may have resulted during shipping. If any damage has occurred, please contact Southpaw Enterprises, Inc. immediately.

Warning:

Failure to properly install a forged steel eyebolt (1/2" or 5/8") may result in serious injury or death. If you have any questions about the installation of the forged steel eyebolt, please contact Southpaw Enterprises Customer Service at 1-800-228-1698.

MATERIALS LIST:

2 - pcs. green strut channel 1-5/8" x 13/16" x 92" length
1 - 5/8-11 x 6' length threaded metal rod

Hardware Pack A:

Contains 4 pre-assembled items. See page 9 for images of pre-assembled items in Hardware Pack A and parts detail list.

Hardware Pack B

Contains 2 pre-assembled items and various small hardware items.

See page 10 for images of pre-assembled items in Hardware Pack B and small parts detail list.

TOOLS NEEDED:

Measuring Tape Level Cordless Drill
(1) 3/8" Drill Bit (1) 1/2" Drill Bit
(1) 3/4" Open-ended Wrench
(2) 5/16" Open ended Wrenches
(2) 9/16" Open-ended wrenches (or socket wrench)

This kit contains everything needed for the average installation. Due to variables beyond our control in building construction (distance between joists, dimension of angle pieces in joist, etc.) you may have to vary from these instructions by replacing a bolt with one of the proper length, or cutting and shortening the length of a strut and/or the threaded rod.

WORKING LOAD: 500 LBS.

Due to manufacturing tolerances there is a small amount of play between the two parts of the hinge.

This play does not affect the strength or safety of the hinge but it does make a slight clicking noise when using a swing on the attachment point. We have included a bent fender washer under the bolt closest to the hinge pivot point. When the bolt is tightened the fender washer will bear on the center part of the hinge and eliminate this play thus quieting the installation (see figure 4).

NOTE: We recommend that you use "Loctite 242 thread locker" on all threaded connections.

ASSEMBLY (see drawings on pages 4—7): Two people required for installation.

- Determine where you want to position the attachment point. The attachment point must be directly on a joist and at least 6 feet away from any walls or other obstacles. Remove the ceiling tile where you will place the attachment point. Make sure that you have no obstructions (heating ducts, wiring, lights, etc.) that will block the brace struts.
- The 1-1/2" square tube (with holes) has a 5/8" hole in the center of two opposite sides. This is the hole for the threaded rod. When locating the tube against the joist, make sure that the 5/8" holes are on the top and bottom. See page 10 for images of assembled square, metal tube with holes.
- Position the tube against the joist where you want the suspension point *making sure that it is level and centered on the joist* (see fig. 2 and/or page 10 lower right corner image). Mark the outside holes on each end of the tube on the joist. Remove the tube and drill a 3/8" hole through the joist at each mark. Put a 3/8" flat washer on each of the two 3/8" x 4" bolts. Put the bolts through the holes in the tube then through the drilled holes pushing the tube against the joist.

- Screw the 5/8" hex nut on the threaded rod until there is 1-1/4" of thread between the end of the rod and the nut. Hold the hex nut and screw the steel ball joint rod end onto the threaded rod against the hex nut. Do not use Loctite and finger tighten only as these will have to be removed later.
- On the opposite end of the threaded rod screw on two 5/8" hex nuts. Put on a lock washer and a flat washer.
- Put the end of the threaded rod into the 5/8" hole in the tube from the bottom. Adjust the upper hex nut up or down while pushing up on the rod until the bottom fender washer at the eye bolt will be even with the bottom of the ceiling tile.
- On the top side of the tube put a flat washer and a lock washer on the threaded rod. Screw two hex nuts onto the threaded rod. Screw the lower nut down against the top of the square tube finger tight. Hold the nut on the bottom of the square tube with one wrench while tightening the nut on the top of the square tube with another wrench. Tighten the nuts enough to compress the lock washers but do not deform the square tube. Screw the second nut on the bottom up against the first one. Hold the top nut with one wrench and tighten the lower nut against it to lock them in place. On the top side of the square tube screw the upper lock nut down against the lower nut. Hold the lower nut with one wrench while tightening the top nut with another wrench.
- Remove the rod end and lock washer from the bottom end of the rod. Screw a 5/8" hex nut onto the bottom of the threaded rod turning it to approximately 3" from the end of the threaded rod. Put a 5/8" lock washer on the threaded rod and push it up against the nut. Use a piece of tape to hold it in place.
- Position strut "A" with the threaded rod through the hole closest to the hinge pin and push the hinge up against the lock washer. Start a 5/8" hex nut on the threaded rod. Screw the nut up against the bottom of the hinge to hold the hinge in place while you attach the top angle bracket to the joist. Position the strut at a 30 to 45 degree angle to the joist. Loosen the bolt holding the angle bracket and slide the bracket to position the attachment hole in the center of the joist. Using the hole in the bracket as a guide, drill a 1/2" hole through the joist. Put a 1/2" x 2-1/2" bolt through the hole in the angle bracket and through the joist. Put a 1/2" fender washer and lock washer on the threaded end of the bolt. Put a 1/2" hex nut on the bolt and tighten it securely against the joist.

Strut B may have to be cut to length, depending on your application.

- Put the bottom hinge of strut "B" on the threaded rod putting the rod through the hole closest to the hinge pin. Turn the strut 90 degrees from strut A towards the adjacent joist that it will be attached to and rest the top end of the strut on the top of the adjacent joist. Put a 5/8" hex nut on the threaded rod. Put the bottom hinge on strut "B" up against the bottom hinge of strut "A" and tighten the bottom hex nut against the hinge finger tight.
- To determine the length of strut B measure from the center pin of the bottom hinge to the lower corner of the joist closest to the bottom hinge. Remove strut B from the threaded rod. Measuring from the bottom of the strut, mark the measured distance on the strut. Loosen the two bolts holding the top hinge and slide the hinge below the mark. Cut the strut to length at the mark. Put the bottom hinge back on the threaded rod, put a 5/8" lock washer and 5/8" hex nut onto the rod. Put the bottom hinge on strut "B" up against the bottom hinge of strut "A" and tighten the bottom hex nut against the hinge finger tight.
- Slide the top hinge up to the end of strut B and position the hinge against the side of the joist so that the hole closest to the hinge pin is located in the center of the joist. Using the hole in the hinge as a guide, drill a 1/2" hole through the joist. Put a 1/2" x 2-1/2" bolt through the hole in the hinge and through the joist. Put a 1/2" fender washer and lock washer on the threaded end of the bolt. Put a 1/2" hex nut on the bolt and tighten it securely against the joist.
- Using a level, position the threaded rod straight vertically. **Tighten All nuts and bolts securely.**
- Measure from the center of the threaded rod to one side and one end of the ceiling tile support frame. Transfer these dimensions to the ceiling tile and cut a 1" diameter hole at this location.
- Put a 5/8" hex nut on the rod and screw it up past the ceiling tile space. Screw the rod end on the threaded rod. Hold the rod end and screw the hex nut down against it and tighten securely.
-

Once installed and in place, there should be no threaded rod exposed from the top nut down to the shackle.

- Put the ceiling tile in place in the support frame with the rod end going through the hole in the tile.
- Lower the ceiling tile into place in the support frame.
- If excessive squeaking occurs, remove shackle and lubricate ball with white lithium grease.

MAINTENANCE CHECKLIST:

All of the following wear points should be checked on a daily, weekly, or monthly basis (as indicated) and recorded on the checklist enclosed.

- Try to turn the eye bolt on a **DAILY** basis. If it turns at all, remove the eye bolt, coupling nut, and lock nuts, clean them, and then re-install per the directions using Loctite 242 threadlocker.
- Check that all nuts and bolts are tight on a weekly basis.
- **WARNING:** Check ceiling eye bolt for wear and movement. If more than 30% of the thickness of the eye bolt is worn away, discontinue use until replaced. If the eye bolt moves excessively, discontinue use until all hardware is checked and tightened.
- Use a Southpaw Safety Rotational Device (#2000) to prevent abnormal wear and damage to equipment.



Take time to familiarize yourself with the use and maintenance of this equipment before using.
Please file this Instruction Sheet in an accessible location.
The Instruction Sheet must be read and familiar to anyone who is using Southpaw Enterprises Equipment.

CAUTION

- ◆ **Check ceiling eye bolt for wear and movement. Do not let wear exceed 30% of eye bolt. If the eye bolt moves excessively, discontinue use until all hardware is checked and tightened. Use a Southpaw Safety Rotational Device to prevent abnormal wear.**
- ◆ **Floor mats of proper thickness should be positioned properly under and around all suspended equipment.**

Safety Precautions - The safety of your clients is dependent on the appropriate choice of activity to match, yet challenge their physical abilities. Use appropriate spotting / safety techniques. In addition, the layout of your activity area, proper installation and maintenance of your equipment is critical. Southpaw equipment is not intended for recreational or outdoor use. Under no condition should this equipment be used without proper supervision.

This sheet is for example only. It is not meant to, in any way, replace local, county, state, or Federal standards. Be aware - it is your responsibility to find all pertinent safety information that pertains to your facility.

If you have any questions or comments, please call or write
Southpaw Enterprises, Inc.
P.O. Box 1047, Dayton, Ohio 45401-1047
Toll Free - (800) 228-1698
Please visit us at southpaw.com
© 2021 Southpaw Enterprises, Inc.

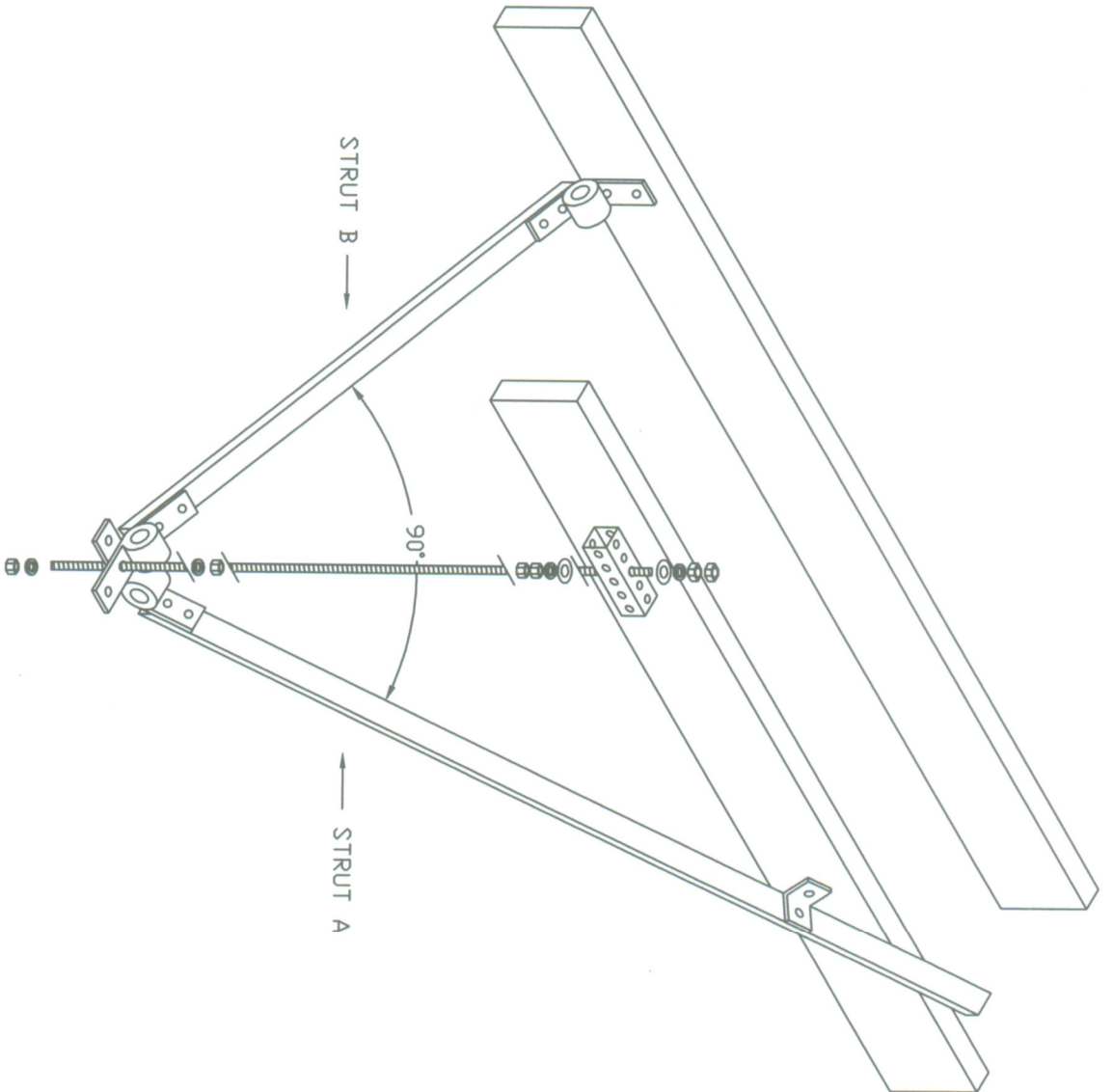

Figure 1

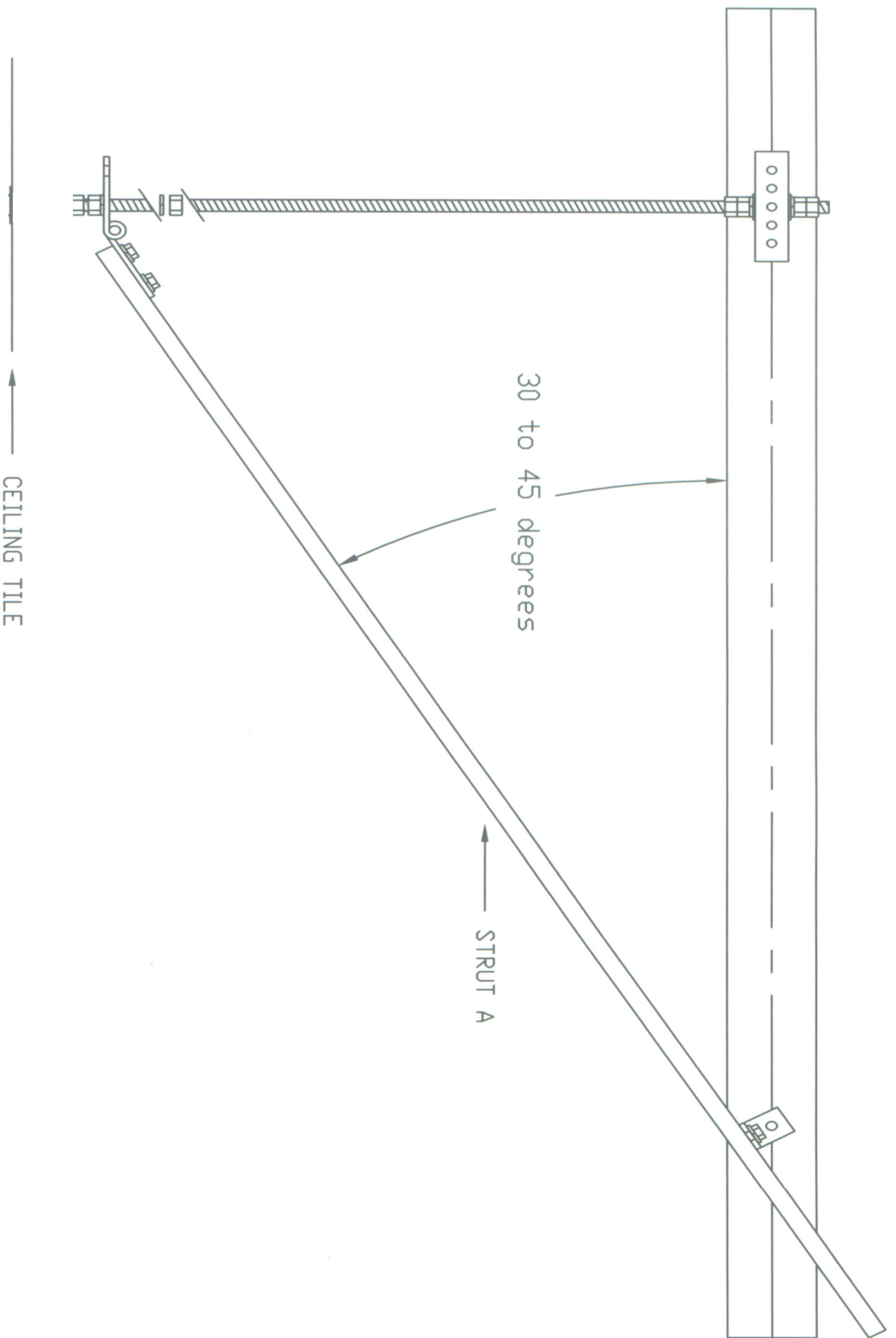

Figure 2

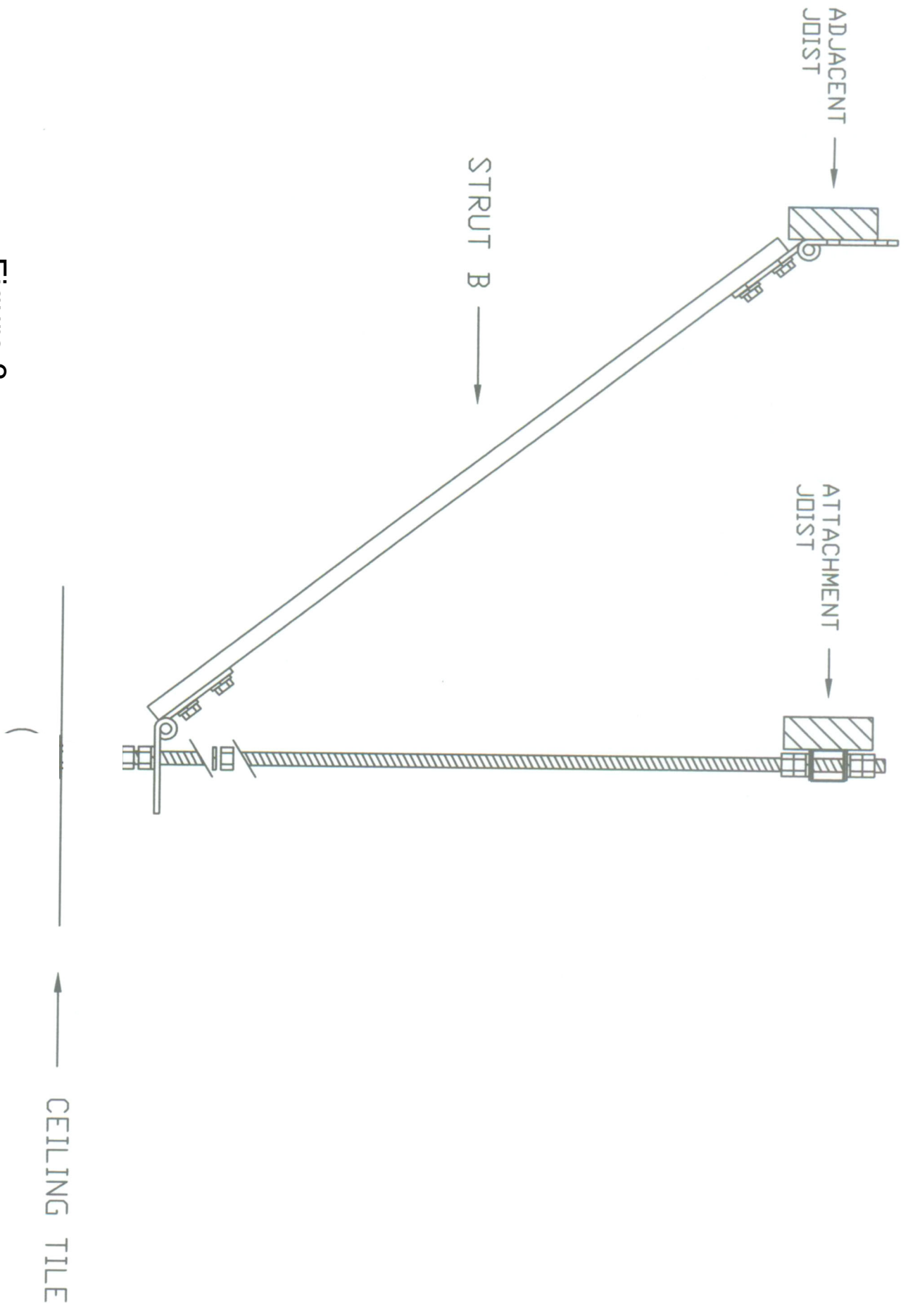

Figure 3

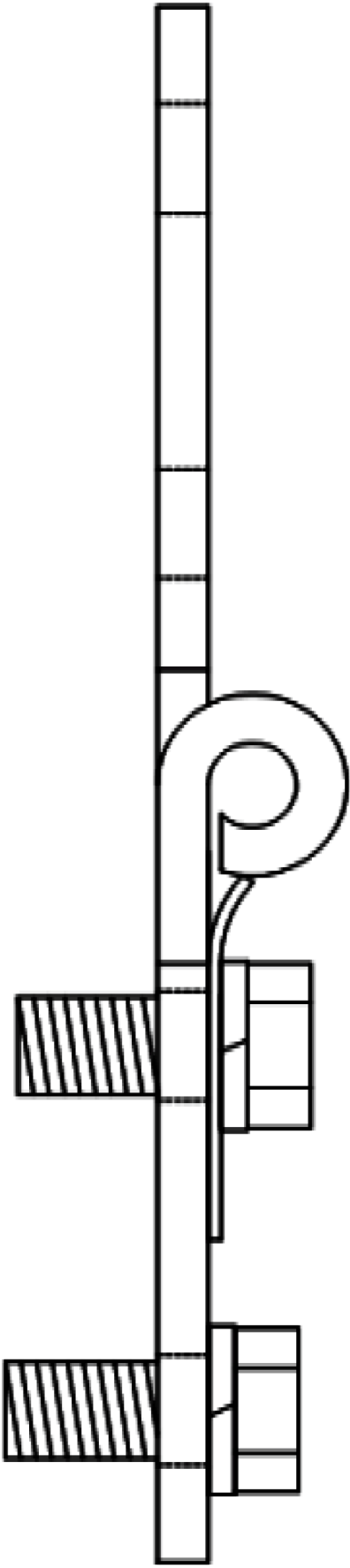

Figure 4

Unpacking the Box:



Hardware Pack A

Hardware Pack A Parts Detail List:



- 2 Four hole hinge assemblies with 2 open holes each
Includes:
 - 1 four hole hinge, green
 - 2 1/2" x 1" hex cap bolts
 - 1 1/2" split lock washers
 - 1 1/2" star lock washers
 - 2 channel nuts
 - 2 1/2" x 1-7/16" fender washers (bent)

- 1 90 degree angle assembly
Includes:
 - 1 1/2" -13 x 2-1/2" hex cap bolt
 - 2 1/2" split lock washers
 - 1 1/2" x 1-7/16" fender washer
 - 1 1/2"-13 nylon lock nut
 - 2 1/2" x 1" hex cap bolt
 - 1 channel nut

- 1 Four hole hinge assembly with 1 open hole
Includes:
 - 1 four hole hinge, green
 - 2 1/2" x 1" hex cap bolts
 - 2 1/2" split lock washers
 - 1 1/2" star lock washer
 - 1 1/2" flat washer
 - 1 1/2" x 1-7/16" fender washer (bent)
 - 1 1/2" x 1-7/16" fender washer
 - 1 1/2" -13 x 2-1/2" hex cap bolt
 - 1 1/2"-13 nylon lock nut
 - 2 channel nuts

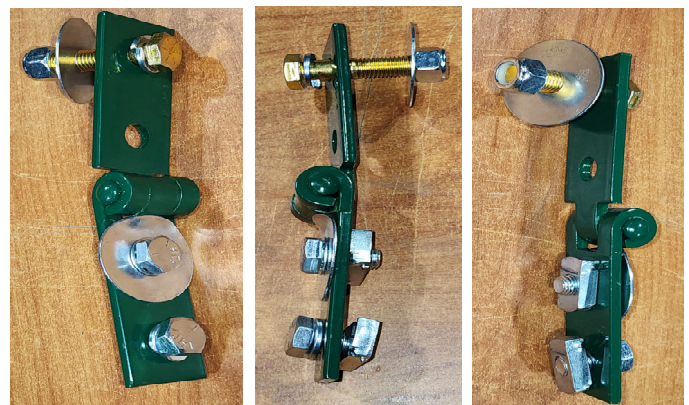
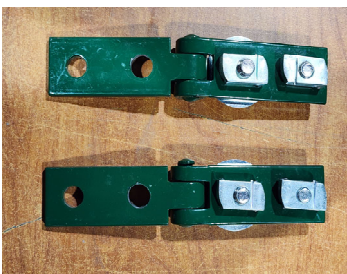
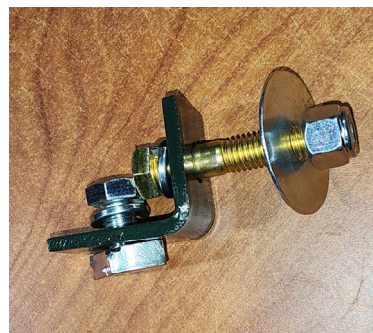
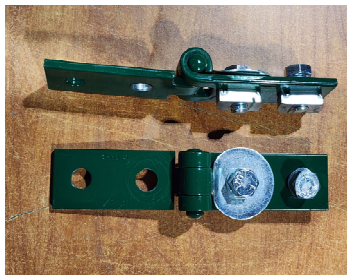
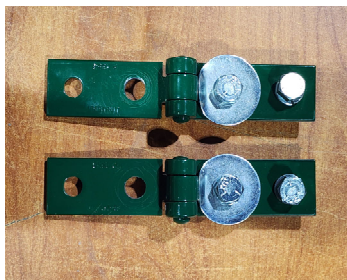

Hardware Pack B



Hardware Pack B Parts Detail List:

- 1 shackle assembly
 - Includes:
 - 1 Shackle 1/2"—13
 - 1 Female Ball Joint Rod End, threaded
 - 1 hex cap bolt, 5/8-11 x 3", GRS Plain
 - 1 5/8"-11 nylon lock nut

- 1 1.5" square metal tube with holes
- 2 hex bolt, 3/8"-16 x 4" length
- 2 split-lock washers
- 2 3/8" fender washers (1-7/16" O.D.)
- 2 3/8" flat washer (7/8" O.D.)
- 2 3/8"-11 Nylon Lock Nut

- 8 5/8"-11 nuts
- 4 5/8" split lock washer, black
- 2 5/8" flat washer

Assembling the 1.5" x 1.5" x 6.0" Square Tube with holes :

